

FEATURES

Body	Forged Steel, T-type
Construction	Swing Check Valve - Pressure Seal Bonnet
Design	ASME B16.34 - EN 12516 - BS 1868 - API 6D
Pressure Testing	ASME B16.34 - EN 12266 - API 598
End Connections	Buttwelding
Options	Auxiliary Connections
Accessories	Weight and Dashpot (others on request)
Body	(S)A105N - (S)A182-F11 - (S)A182-F22 - (S)A182-F91 - (S)A182-F92 (others on request)
EN-materials	1.0460 - 13CrMo4.5 - 10CrMo9.10 - 1.4903 - 1.4901 - 1.6368

ASME CLASS:
2500

EN CLASS:
PN 400 - 500

MATERIALS

01. Body	(S) A105N (see above)
02. Bonnet	(S) A105N
03. Cover	A105
04. Bonnet Bolting	A193-B7 / A194-2H
06. Segmental Ring	13 CR
07. Thrust Ring	13 CR
08. Gasket	Graphite / S.S.
09. Disc	A105 + Stellite
11. Disc Nut	A276-410
12. Hinge	A216 WCB
13. Hinge Pin	A276-410
14. Retainer	A276-410
15. Bonnet	A105
17. Hinge Pin Bearing	13 CR + Stellite
18. Hinge Pin Gasket	Graphite
19. Nut	A194 2H
22. Pin	A276-410
23. Seat Ring	A105 + Stellite
24. Lift Eye Bolt	Carbon Steel

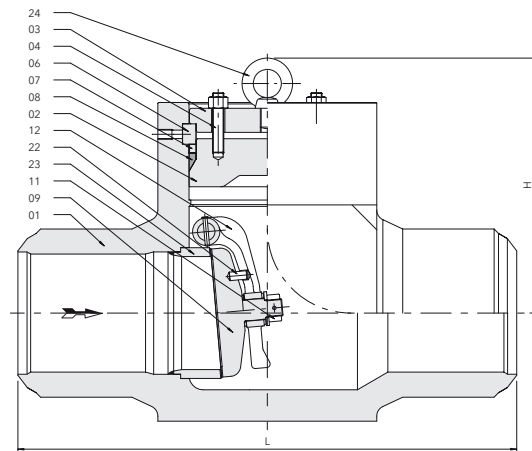
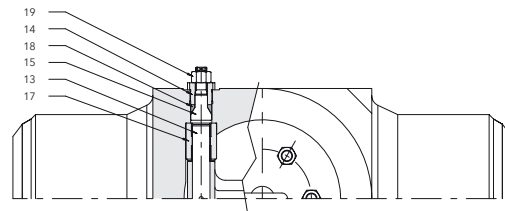

MAIN DIMENSIONS IN MM (INCH)

NOM. SIZE	L	H	CV	WEIGHT KG
150 (6")	610 (24.0)	332 (13.1)	620	235 (518 LB)
200 (8")	762 (30.0)	342 (13.5)	1080	380 (838 LB)
250 (10")	914 (36.0)	398 (15.7)	1720	695 (1532 LB)
300 (12")	1041 (41.0)	444 (17.5)	2410	1.070 (2359 LB)
350 (14")	1118 (44.0)	495 (19.5)	2900	1.290 (2844 LB)
400 (16")	1245 (49.0)	580 (22.8)	3760	2.020 (4453 LB)
450 (18")	1346 (53.0)	692 (27.2)	4500	2.310 (5093 LB)
500 (20")	1448 (57.0)	750 (29.5)	5700	3.640 (8025 LB)